



European Web Platforms and Training Concepts
for Intermodal Inland Waterway Transport



MARCO POLO
NEW WAYS TO A GREEN HORIZON

EWITA NEWS +++ EWITA NEWS +++ EWITA NEWS +++ EWITA NEWS +++ EWITA NEWS

EWITA NEWSLETTER NO. 1

JUNE 2009

e-Learning: Connecting European Waterways

“EWITA” is short for **European Web Platforms and Training Concepts for Intermodal Inland Waterway Transport**. It is funded within the **Marco Polo II programme** of the European Commission and will provide up-to-date training concepts and state-of-the-art e-learning web platforms for intermodal Inland Waterway Transport (IWT) in Europe. The project started on June 1, 2008 and will run for two years.

EWITA is a **follow-up of eWIT** (www.ewit.info), whose main results were a European Concept for intermodal IWT training in Europe and INeS, the Inland Navigation eLearning System (www.ines.info) for the Danube region based on the Concept. Within EWITA, the European Concept of eWIT will be substantially updated and extended with respect to learning levels, content, tools and languages. INeS (Inland Navigation eLearning System) will be adapted

accordingly and renamed into **INeS Danube** and an additional e-learning platform for the Rhine-Maas-Schelde corridor – **IneS RMS** – will be created. Both platforms will be available in several languages.

The EWITA platforms will combine European with specific regional or national content. To facilitate update and synchronization, a **pan-European content repository** will be designed, allowing for a smooth administration of common learning objects available for the different topics. Innovations of EWITA will also include the design of learning groups for specific target users of the platforms, additional multimedia elements and modern learning technologies (e.g. animations, interactive elements, streaming video and sound).

Dissemination & Promotion of EWITA

WEBSITE

Having an attractive and informative project website is one of the most crucial cornerstones of a comprehensive Dissemination & Promotion strategy. The EWITA website aims to satisfy this need.

The website is available at www.ewita.info and includes **four sections**. Within the **about EWITA** section, the website visitors can find a short introduction to EWITA, its objectives, a list of the project partners, an overview of the participants of the industrial and educational user forums as well as a short review of the predecessor project eWIT.

The next two sections inform about the most important expected results of EWITA: the **two E-Platforms INeS Danube and INeS RMS** as well as the **Common European Content Repository**. Currently, the project partners are working on the content for the specific learning modules.

INeS Danube and INeS RMS shall be launched in the first quarter of 2010.



Figure 1: Screenshot EWITA Website

The fourth section of the Website is the **Service area**. At the moment, it includes regular project news as well as the project partners login to eGroupware, their tool to manage contacts, meetings, tasks and documents.

LEAFLET

A project leaflet is another very important Dissemination & Promotion tool.

The EWITA leaflet was finalised at the beginning of 2009 and contains a description of the project itself, the project aims, a list of the project partners and a definition of the potential target groups.

It can be downloaded at www.ewita.info or ordered at ewita@ewita.info.



Figure 2: EWITA Leaflet

LOGOS FOR THE TWO E-PLATFORMS

The logos for the two e-platforms INeS Danube and INeS RMS have been designed by the project partner Imagination.



Although the two e-platforms will be operated separately, the look & feel shall be similar. That's why the two logos differ in their colour and wording only.



EVENTS

Attended Events

The project consortium presented EWITA and/or prepared a paper for submission to:

- **POWA** Conference:
18-19 September 2008, Croatia
- **EDINNA** Assembly Meeting:
4 February 2009, The Netherlands
- **Arbeitskreis eTrade & Transport** (working group of the Austrian chamber of commerce):
26 February 2009, Austria
- **eLSE 2009**: e-learning conference:
9-10 April 2009, Romania

- **Transport and Logistics 2009**:
12-15 May 2009, Munich

Furthermore, **two User Forum Workshops** have taken place. In September 2008, educational institutions as well as industrial members participated in the workshop in Vienna. The workshop in Rotterdam took place in January 2009 with an audience of educational institutions. During the workshop the project team introduced the first INeS RMS learning module 'locks' to the participants.

Upcoming Events

The project consortium plans to present EWITA and/or to prepare a paper for submission to the following events within the next six months:

- **Smart Rivers '21**:
6-9 September 2009, Austria
- **8th International ILIAS Conference**:
12-13 November 2009, Hungary

Furthermore, the following events will be organised by EWITA project partners:

- **Rivershow for educational users**:
September 2009 in the port of Antwerp, Belgium
Hosted by PBV
- **Rivershow for industrial users**:
September or November 2009 in the port of Galati, Romania.
Hosted by CERONAV

Common European Content Repository

One of the main objectives of the EWITA project is the creation of a **common European content repository (ECR)** for intermodal inland waterway transport (IIWT) education and training.

Reusable learning objects (RLOs) are the basis for the creation of e-learning materials, and content repositories are an essential component for using and sharing digital learning objects within an e-learning community. On a very general level, a repository can be defined as a system that stores electronic objects and metadata about those objects. In addition to this core functionality, repository projects with a community building focus like EWITA should provide a set of services that encourage the development and the use of educational materials in the field of intermodal inland waterway transport.

Therefore, EWITA's pan-European content repository (ECR-IIWT) should (a) **enable the shared and common use of digital learning resources** for intermodal inland waterway transport across all regional implementations of EWITA's e-learning platforms (using the open-source software ILIAS as learning content management system) and (b) **make these resources accessible free of charge** for any interested party or web-based application searching the repository.

The **system architecture** of the repository must ensure that reusable learning objects (these can be assets, i.e. single files, or content packages, i.e. learning modules or courses consisting of a collection of several files) will be stored only once, thus preventing unnecessary duplications of existing content.

Central and consolidated data storage in a content repository will facilitate a transparent and easy-to-handle release and update management. EWITA's web platforms (INeS Danube and INeS RMS – Rhine-Maas-Schelde) as well as future platforms (INeS [n]) which are outside the scope of the EWITA project can make use of content elements stored in the repository which are specifically needed for their geographical region and/or target groups.

The learning modules produced in EWITA will be available under the **Creative Commons Licenses** (likely by-nc-sa). This means that they can be downloaded from the repository and included in other Virtual Learning Environments (VLE). This way, potential users, like schools, may access the learning materials through one of the INeS platforms or their schools' own VLE. Altogether this will increase the number of users and improve dissemination of the EWITA platforms.

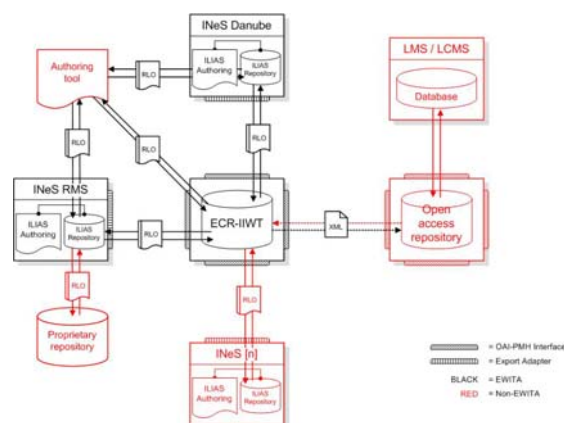

Figure 3: Architecture Content Repository

EWITA Contact

Dissemination and Media

Simona Tomarchio
European Intermodal Association

Rue d'Arenberg 44
B-1000 Brussels

Tel.: +32 (0) 2 514 56 54
Fax: +32 (0) 2 514 67 60
Email: simona.tomarchio@eia-ngo.com
Web: www.eia-ngo.com

Project Coordinator

Sabine Piribauer
via donau –
Österreichische Wasserstraßen-
Gesellschaft mbH

Donau-City-Strasse 1
A-1220 Vienna

Tel.: +43 (0) 50 4321 1405
Fax: +43 (0) 50 4321 1450
Email: sabine.piribauer@via-donau.org
Web: www.via-donau.org

ewita@ewita.info | www.ewita.info